

A RESEARCH ON SMART VEHICLE PARKING SYSTEM

Dipali Balmiki², Manas Singhal¹, Anupama Singh², Divyangi Tyagi²,

¹Assistant Professor, Electronics and Communication Engineering department, Moradabad Institute of Technology, Moradabad

²Student, Bachelor of Technology (ECE), Moradabad Institute of Technology, Moradabad

ABSTRACT

As today where the count of number of vehicles on the road is increasing rapidly. So with the increasing number of vehicles traffic problems are bound to exist. The project entitles "Smart Parking System" present an automatic IoT based smart vehicle parking system. The problems faced in metropolitan cities on roads can be solved by this SPS. The main disadvantage in the existing system is tracing the amount deducted and it varies time to time on different slots. In this system the custodians can easily find out the vacant parking slots. Here the same gate used for exit (where is the same the entrance gate in this project) count in reverse order for the cars when the car goes out from the park. This project aims at the interfacing RFID concept with Internet of Things (IoT). Smart parking system helps in reducing the consumption of fuel and decreases the pollution in urban area which help to increase the economy of the country.

KEY WORDS: Smart parking system, Iot, RFID

I. INTRODUCTION

The Internet of Things (IoT) is the network of different physical object such as device, vehicle, buildings and other items – which are embedded with electronics components, software, different sensors, and network connectivity by the help of these objects system collect and exchange data as the family count is increasing with the total number of vehicles are also increasing, the parking situation is going worst day by day of the current requirements in the country. This ensure minimization and solve the traffic constraints in parking areas. In Asia, roads are narrow which cause these types of problems.

There are many solutions have been provided to control traffic problems till date. So this paper mainly focuses to overcome the traffic problems and parking issues thus the named of system is smart vehicle parking system using RFID and IoT. There are many factor which effects the parking system. This system uses RFID in order to provide high identification accuracy, efficient management of parking slots, easy in-and-out access for drivers with least human intervention, low deployment, operation and maintenance cost.

II. LITERATURE REVIEW

A. Parking system based on image processing:

A unique identification number is required and for this number plates can be a useful identification by identifying and capturing with the help of number plates. This method can be useful to manage the parking area and same can be used for payments.

1. Advantages

Firstly, this system captures the image of parking lots and then it will give the information regarding the availability of free parking space and the picture will capture in rounded image. By the help of Camera, we can saw the engaged condition of car parking. By using a single camera, we can detect

many vehicles in the parking area And it will use like sensor to take photos of vehicles.

2. Disadvantages

The main disadvantage of this system is when the weather is bad then its effect on the clarity of the vehicles. The camera should be placed at a good position where it can see all the car park and there is no interference by any object. There is no guidance is provided in the parking lot.

B. Automated parking system with Bluetooth access:

This system requires a Bluetooth device. This device will find the vacant slot in parking. And within the range of bluetooth device whatever the information would collect it will be transfer to the user.

1. Advantages

User can use the mobile's Bluetooth to register and identify the parking space. And the mechanism which will help to find out the location to transport the vehicle is rack and pinion mechanism. When a new vehicle is to be parked bluetooth chip will automatically detect the unique identification number.

2. Disadvantages

The existing system cannot adopt this. The mechanism which is required to design the whole parking lots mechanically is rack and pinion.

C. Car park management, with networked wireless sensors and active RFID:

This system uses networked wireless sensors to monitor the cars in the parking area. For the unique identification of cars, every car must have an RFID tag which would be embedded in it.

1. Advantages

This system will be very effective in the terms of simplicity and cost management for the user over lot management model. Gate management services: As an example, a gate can be opened automatically using an RFID reader and the vehicles tag at the gate.

2. Disadvantages

No driver guidance system to guide towards the parking lot.

III. METHODOLOGY

A. EXISTING METHODOLOGY

The smart vehicle parking system which developed with the incorporation of advanced technology and research from different academic disciplines are executed mainly in the Europe, United States and Japan (Shaheen et al., 2005). By these developments in the system, it is hoped that it would solve the aforesaid problems faced by the frequenters within the car park.

The aim of existing methodology is to use Radio Frequency Identification (RFID) technology in automation of vehicle parking system in mall/building. The system also gives an efficient and an alternative method to pay and display tickets to coin operate methods. this project is Simple and cost effective to implement it is a standalone system or alongside it also abolishes fraud and reduce cash handling process which was provided in traditional parking payment system. This new SPS provides a feature that whenever any user wants to park his vehicle then he would be able to check and given availability of parking slots in nearest parking area. And there is a major focus in this system which has been found is that it will help to reduce time taking in finding the parking area. Because there is a lot time wastes when a user has to park vehicle in travelling via filled parking. Thus the consumption of fuel will be reduced by this. And when the consumption of fuel will be less then carbon footprints in atmosphere will also be reduce.

IV. DRAWBACK OF EXISTING METHODOLOGY

- i) Priority on booking of slots is not enabled so the booking of slots for multiple users at the same time is not configured.
- ii) By the help of RFID concept its is not possible to pre-booked of slots which helps to minimize the traffic problems.

iii) This is a user friendly application but there is a major drawback for payment gateway.

V. PROPOSED METHODOLOGY

In this new system two technologies will be used RFID and IoT. In this project, SPS build with IoT which gives the availability of vacant parking lots in the parking area and allow the user to find the nearest park area has been designed. And there is a major focus in this system which has been found is that it will help to reduce time taking in finding the parking area. And to avoid traffic at an area.

There is one more purpose of this system that to reduce the worker's number in the garage. Because at the entry there is always a 7-meter counter to countdown. While, the exit will be count in ascending order or according to what is done in the coding of Arduino programming and it will absorb the number of vehicles to be inside the garage. The door of the garage automatically closed when there is the highest value of the meter and cannot be opened until the next new cars entered and this project can be added by several devices that help the person to gain time and reduce the congestion caused by protrusion such as the depletion of the GPS. After reaching the slot every driver owning the vehicle parking card also known as the RFID tag should show it in front of RFID reader.

This card has the information regarding parking. In the center of parking card reader will be fixed. When user have to park the car they will require to show the RFID card. Entry gate will have the card reader installed at starting. Whenever the driver owns his car with RFID card and that RFID card will hold the amount also of the fees. The RFID card reader reads the timing of incoming of car on the entry gate and passes the information to the microcontroller. And when the user will go out the reader will read the timing of outgoing from the parking. The in and out time will be used to calculate the amount of fees.

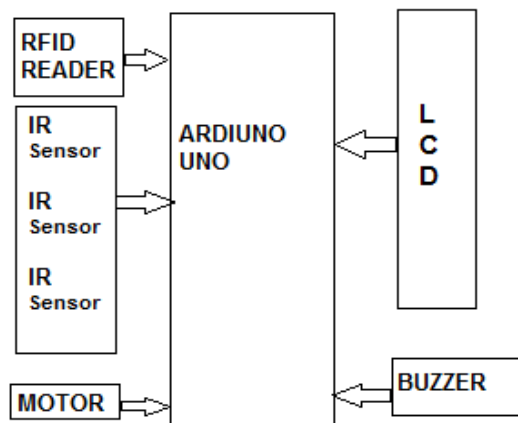

Fig 1: Block Diagram of Proposed system

VI. RESULT

The demand of smart vehicle parking system is increasing very fast. This allow user to involve real time access of the availability of the parking space.

The existing system in today's world doesn't contain the facilities of parking reservation and parking slot availability checker. The result of this paper is to make the parking area connected with the world as well as reduces time and can be cost effective for the user. To stop car thieving also this system is introduced. This paper reduces overall fuel energy of the vehicle which is consumed in the search of the car.

VII. APPLICATIONS

This is system is also efficient for car parking. And it prevents from traffic congestion too. Can be implemented in mall, hospitals and multi store building. The time which take in the process it can be made short and easy to configure. In this booking will be easier. And the payment method is also manual therefore we don't need to worry about online transaction.

VIII. CONCLUSION

The Smart Vehicle Parking System is an IoT based system which provides a solution for all the existing problems of parking system. The proposed system is simple and economic to deploy and also helps to reduce the carbon footprints emitted due to the vehicles waiting for parking slots. This system minimizes the parking waiting time in the large-sized parking facilities.

It also helps in solving problem of illegal parking and reduction of the traffic jam on the roads. It would also help reduce the man-power in the parking areas which would greatly reduce the cost and error in the process as it has all the records of each vehicle. It also helps to detect the theft cars which are very useful nowadays. Thus this new parking system can solve all the challenges for all traffic related issues.

IX. FUTURE SCOPE

The concept of smart cities has always been a dream. Our future work is to create car parking system to work as an operational platform in a smart city. There will be a high authority to get access of information managed by the car parking system center, for the relevant management and control entities, including a highway Centre, emergency Centre, traffic control Centre, and police. The sensor after sensing the information regarding vehicle lots it will send the updated information to parking meters, which will forward this information to the information center.

REFERENCES

- [1] Penttila, K., Keskilammi, M., Sydanheimo, L., Kivikoski, M., 2006. Radio frequency technology for automated manufacturing and logistics control. *International Journal Of Advanced Manufacturing Technology*, 31 (1-2): 116-124.
- [2] Zhang, L., 2005. An Improved Approach to Security and Privacy of RFID application System. *Wireless Communications, Networking and Mobile Computing. International Conference.* (2): 1195- 1198.
- [3] Higgins, N., L., Cairney, T., 2006., RFID opportunities and risks. *Journal of Corporate Accounting & Finance*, Vol, 17 (5):51-57.
- [4] Xiao, Y., Yu, S., Wu, K., Ni, Q., Janecek., C., Nordstad, J., 2006. Radio frequency identification: technologies, applications, and research issues. *Wiley Journal of Wireless Communications and Mobile Computing.* (accepted for publication).
- [5] Goodrum, P., McLaren, M., Durfee, A., 2006. The application of active radio frequency identification technology for tool tracking on construction job sites. *Automation in Construction*, 15 (3): 292-302.